

Fiber Media Converters

Industrial Media Converter Mini

Features

- Industry's smallest miniature design
- 1 x 10/100 (Fast Ethernet) RJ45 Network port
- 1 x 100BASE-LX SC duplex single-mode port
- Extends 10/100 Ethernet up to 20km / 12.5mi over single-mode fiber
- Compliant with IEEE802.3 standards
- Autosensing MDI/MDIX crossover on network port
- LED indicators for network signals, link status and power
- Made in the U.S.A.

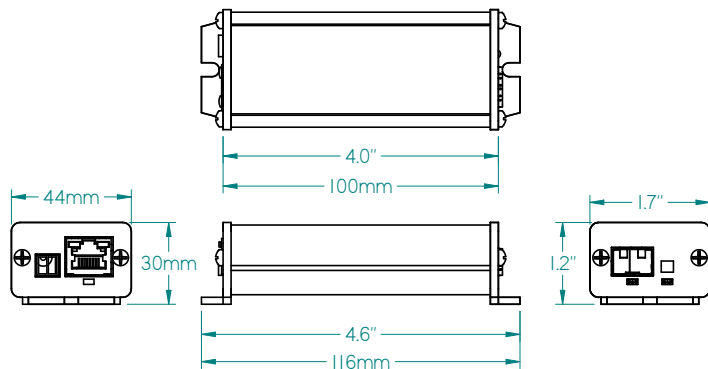

Technical Specifications

Network Port:	RJ45 Connector
Optical Port:	Duplex SC 1310nm for use with single-mode fiber
Ethernet:	10/100Mb on copper port, full or half duplex
Ethernet on Optical Link:	100Mb full duplex
Max operating distance electrical:	up to 100m / 330ft on Network Port (10/100 copper)
Max operating distance optical:	up to 20km / 12.5mi using SC duplex single-mode 9um fiber
LED Indicator:	Orange/Green Flashing LED for 10/100BASE Electrical link and activity Green/Flashing LED for optical link and activity Green LED for Power
Optical Wavelength:	1310nm
Optical Launch Power:	-3dBm (max) to -9dBm (min)
Minimum Receiver Sensitivity:	-32dBm @ 1x10E-10 BER
Receiver Overload Power:	-3dBm
Minimum Optical Budget:	23dB
Operating Temperature Commercial:	-40C to 75C / -40F to 167F
Humidity:	Up to 95% non-condensing
System Latency:	<1mS
Power Requirement:	12-30VAC / 12-57VDC
Power used:	2 watts
BTU Rating:	6.8BTU/hr
Shipping Weight:	0.45kg / 1lb
Shipping Size (HxDxW):	64mm x 133mm x 189mm / 2.5" x 5.25" x 7.45"

Common Installation

