

# Model ET1543C

# Installation and Operation Manual



Reduce risk of fire or electrical shock. Do not expose this product to rain or moisture.

**Note:** This installation should be made by a qualified service person and conform with local codes.

## Introduction

The ET1543C is designed for use with the ER8500C and ER16500C. Please refer to the ER8500C or ER16500C manual for installation and operation related to the ER8500C and ER16500C.

## ET1543C Transmitter-end Installation

- 1) At the camera (or other Ethernet device) location securely mount the transmitter unit.
- 2) Find the coaxial cable from the head-end and make sure it is properly terminated RG59 or RG6 (75 ohm type) solid copper cable. Connect coaxial cable to the BNC jack of the transmitter. If the head-end unit is powered up, it will sense the connection to the transmitter unit and turn on the power. This will be indicated by the green POWER LED on the "Network Port". After about 15 to 30 seconds the green 10/100 LED for the "Coax Port" will turn-on to tell you that the head-end has connected with the transmitter unit. The Ethernet device (camera) does not need to be connected for the transmitter to communicate with the head-end.
- 3) Finally, connect an Ethernet device to the transmitter "Network Port". If the device requires PoE power, the POE OUT LED will turn on followed by the LINK LED on the "Network Port". The IP camera (or other Ethernet device) should now be ready to operate. Continue installing the remaining transmitters as needed.

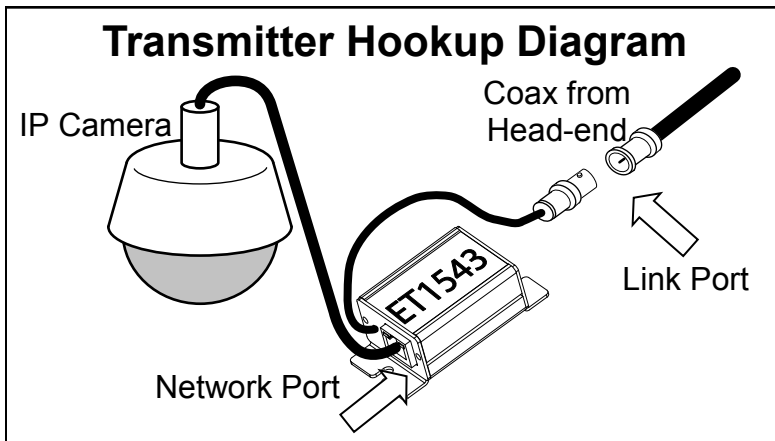

PoE Device Power RG59 Coax *	
Distance	Power at PoE Port
328ft/100m	21 watts
656ft/200m	16 watts
984ft/300m	15.4 watts
1312ft/400m	14.4 watts
1640ft/500m	12.2 watts

\*Results with ER8500 Receiver and using RG59 SBC Type Cable with 20AWG Center

LED INDICATORS			
LED	OFF	ON	FLASHING
Power	No Power	Power Good	
Link	No Ethernet Link	Ethernet Link Good	
PoE Out	No PoE Power Out	PoE Power Good	
Coax 10/100	No Link	100Mb	10Mb

Patent Pending USA and Europe  
Euro Pat App 2779641



# NITEK®

USA

729 1st Ave N  
Birmingham, AL 35203  
Phone: (847) 259-8900 Fax:  
(847) 259-1300  
E-mail: info@nitek.net  
WWW.NITEK.NET

## Optional Hookup for High Power PoE Devices ET1543C Units

- 1) In some cases the PoE device connected at the transmitter end needs more power than can be supported over a long coaxial run. You can usually identify these cases by watching the POWER LED of the transmitter, located on the "Network Port". If the power light cycles ON for less than 1 second and then is off for 3 or 4 seconds when the PoE device is connected, but it turns ON and operates normally without a PoE device connected, this would indicate you are having a current limit problem.
- 2) You should first check the power requirements of the PoE device. Also check the length of the coaxial cable. The POE POWER CHART on the previous page will indicate the maximum power available for your length of coax.
- 3) If the needed level of power is not available for the length of coaxial cable, alternate options are available. One method is to directly power the transmitter with a 48VDC power supply as shown below (Nitek# PS48). When powered directly from a 48VDC supply the transmitter can deliver full 802.3AT power regardless of the coaxial cable length plus an additional length of up to 100 meters of network cable.

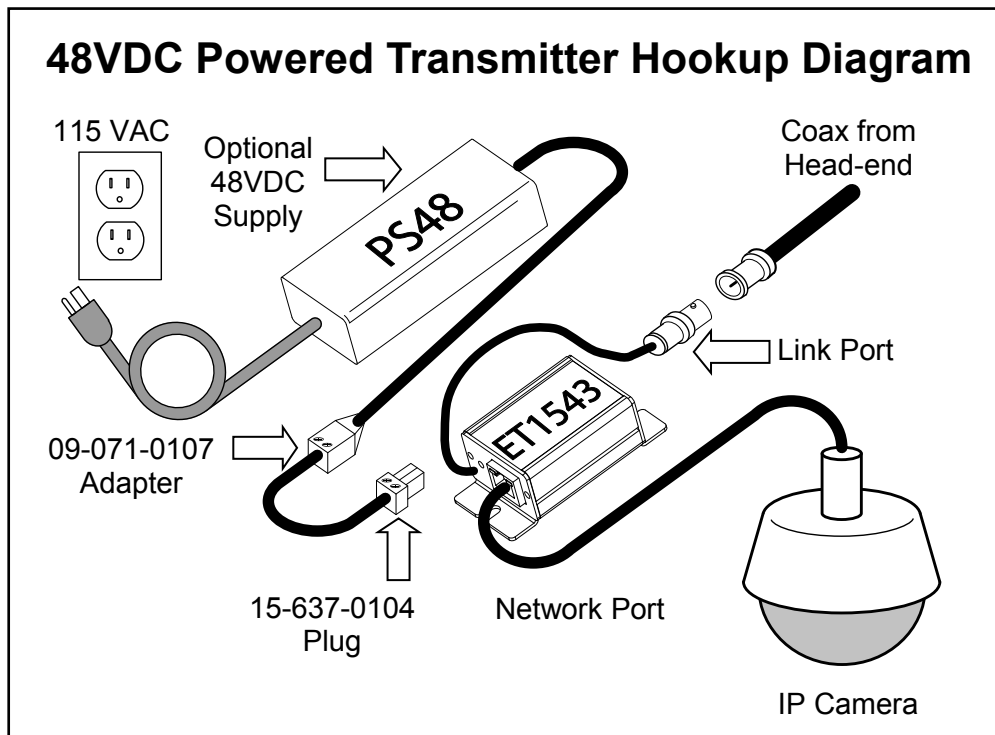

Transmitter used as PoE Injector*	
Distance from Network Port	PoE Device Power Available
33ft/10m	33 watts
328ft/100m	26 watts

\*Results with 48VDC power to the Transmitter optional Power Port