

Model ER1500C (for use with Coaxial cable)

Pairs with: ET1543C, ET1500C, and ET4500C Transmitters

Compatible with: IPCOAX, PS48, and WP1325 accessories

Installation and Operation Manual



Reduce risk of fire or electrical shock. Do not expose this product to rain or moisture.

All installation diagrams include manufacturer recommended surge protection (such as the IPCOAX1) on both ends of the transmission line. Basic installation does not require surge protection for operation.

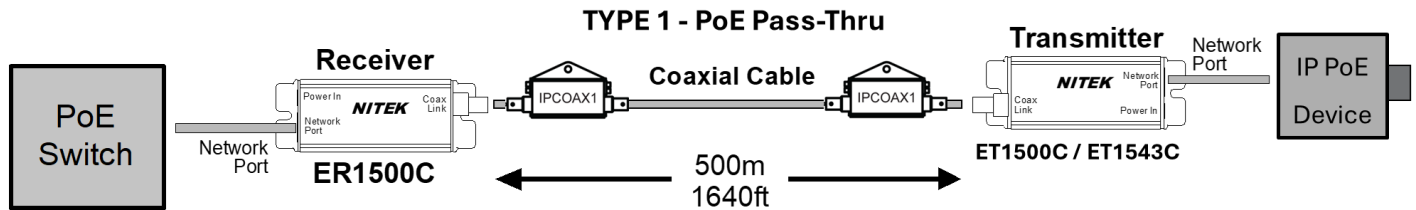

TYPE 1 Installation— PoE Pass-Thru configuration

- Connect the PoE Switch to the Network port on the ER1500C.
- Connect the BNC cable to the Link Port of the ER1500C.
- Connect the opposite end of the coaxial transmission cable to the Link Port of the Transmitter device.
- Once connected, the device will automatically initialize and establish the duplex communication link.

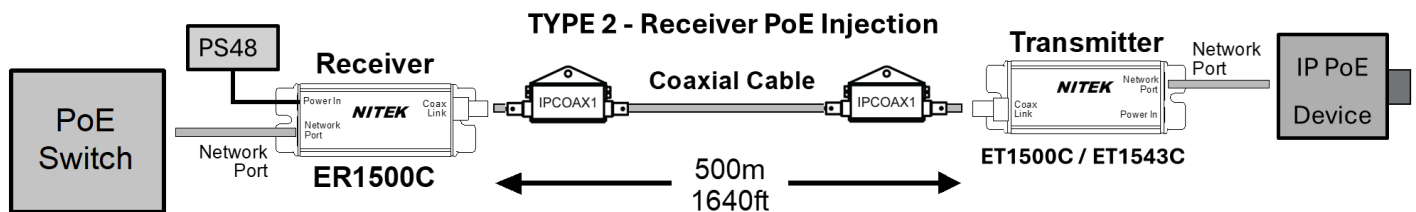

TYPE 2 Installation— Receiver Locally Powered

- Connect the PS48 power supply to the power-in port on the ER1500C Receiver.
- Follow TYPE 1 Installation procedure.

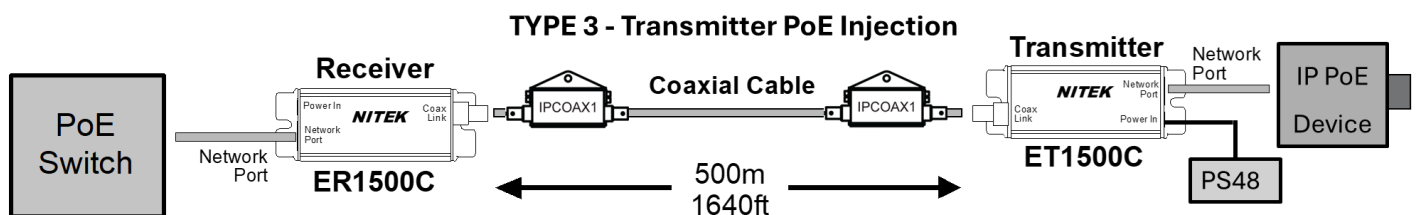

TYPE 3 Installation— Transmitter Powered

- Connect the PS48 power supply to the optional power input port on the ET1500C Transmitter.
- Follow TYPE 1 Installation procedure.

NITEK®

729 1st Avenue North
Birmingham, AL 35203
Phone: (800) 528-8502
E-mail: info@nitek.net
WWW.NITEK.NET

TYPE 4 Installation — Use with ET4500C Switch

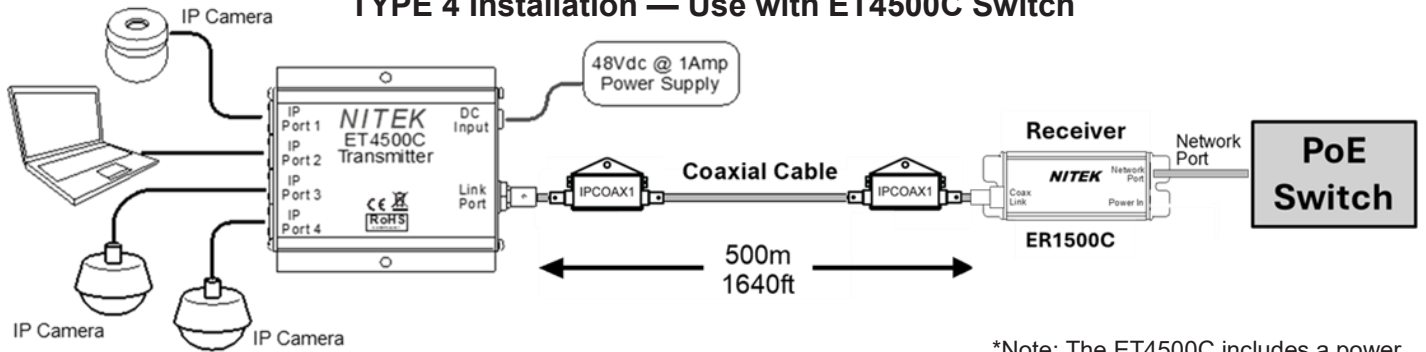

*Note: The ET4500C includes a power supply required to operate the Switch.

TYPE 4 Installation— Use with ET4500C Switch

- Connect the PoE Switch to the Network port on the ER1500C.
- Connect the BNC cable to the Link Port of the ER1500C.
- Connect the opposite end of the coaxial transmission cable to the Link Port of the ET4500C Transmitter device.
- Once connected, the device will automatically initialize and establish the duplex communication link.

TROUBLESHOOTING

1. Check status LED's (see reference table below)
2. Ensure cables are not damaged and verify signal continuity
3. Ensure that cables are properly terminated and securely connected
4. Verify the connected PoE device is independently functional
5. For additional support, contact customer service at the phone number or email provided.

PoE Device Power RG59 Coax with 20AWG Center*

Distance	Power at PoE Port
328ft/100m	15.4 watts
656ft/200m	13.0 watts
984ft/300m	11.3 watts
1312ft/400m	9.3 watts
1640ft/500m	8.0 watts

*Results with 48VDC power to the Receiver optional Power Port and using RG59 SBC Type Cable

Transmitter as PoE Injector*

Distance from Network Port	PoE Device Power Available
33ft/10m	33 watts
328ft/100m	26 watts

*Results with 48VDC power to the Transmitter optional Power Port

LED INDICATORS

Connector	LED	OFF	ON	FLASHING
Network Port	Power	No power	Power Good	
	Link Status	No Ethernet Link	Ethernet Link Good	
Link Port	PoE Out	No PoE Power Out	PoE Power Good	
	10/100	No Link	100Mb	10Mb

 E325724
US LISTED
I.T.E.

IEC/UL 60950-1



 RoHS
COMPLIANT
2002/95/EC



NITEK®

729 1st Avenue North
Birmingham, AL 35203
Phone: (800) 528-8502
E-mail: info@nitek.net
WWW.NITEK.NET