

# Installation Instructions

## VH451 4 Channel Hub

®

**Note:** This installation should be made by a qualified service person and conform with local codes.

5410 Newport Drive, Suite 24  
 Rolling Meadows, IL 60008  
 PHONE (847) 259-8900  
 FAX (847) 259-1300  
 Internet: www.nitek.net

 Reduce risk of fire or electrical shock do not expose this product to rain or moisture.

### Specifications

**VH456** System includes the following:  
 (1) VH451 Hub  
 (1) Wall power transformer

**Size** 1.8"H x 5.5"W x 4.6"D  
**Power Requirements** 24VAC @350mA  
**Input** UTP video  
**Output-Video** 1.0 vpp comp. video  
 Monochrome or Color

### VH451 Dimentional Diagram

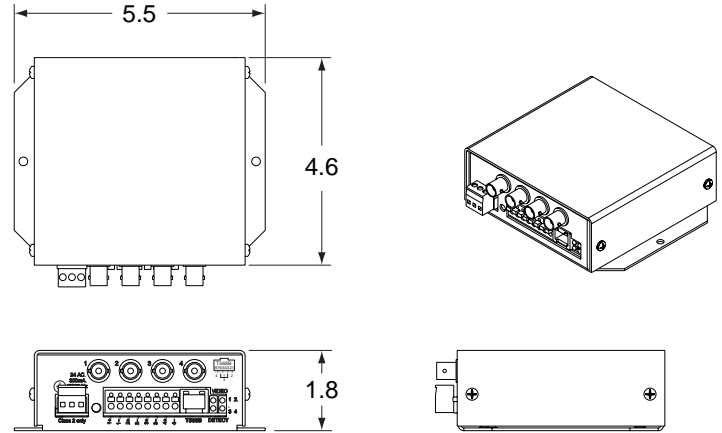

### Introduction

This sheet is designed to cover the VH451 receiver hub. The VH451 receiver can be hooked up to several different Nitek UTP passive transmitter units. The passive transmitter requires no power and can provide video up to 1500 feet. For longer distances consult Nitek for other available systems.

### VH451 common hookup diagram

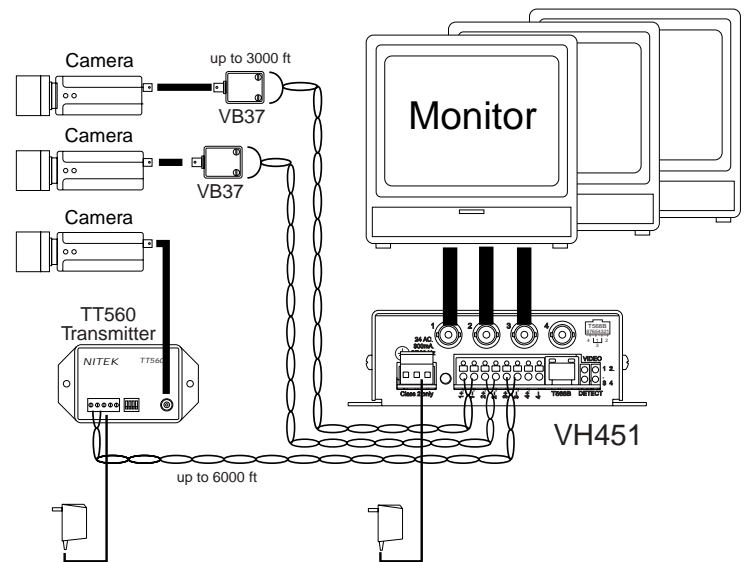

### Determining Cable Length

Check the twisted pair for continuity. Do this by shorting the pair of wires at one end and use an ohm meter to check the resistance at the other end. Use the chart to determine the length of your wires for a measured resistance. Also, use the multimeter to test the line and make sure there is no voltage on it. Testing each line and recording the length for each camera run can greatly reduce installation time. For distances greater than 3,000 feet an amplified transmit source may be needed.

WIRE GAGE	DISTANCE IN FEET (METERS)						
	500 (152)	1,000 (304)	2,000 (610)	3,000 (914)	4,000 (1219)	5,000 (1524)	6,000 (1829)
22	16	32	64	97	129	161	194
24	26	51	103	154	205	257	308
26	41	82	163	245	326	408	490

## VH451 w/Passive (Balun) Transmitter

**1. Connect Balun to camera** - Using the installation manual provided with the balun connect it to the video source, usually a video cameras. If you have a UTP ready camera connect the twisted pair directly to the camera video out.

**2. Connect twisted pair to VH451** - The twisted pair can be connected to either the push-in terminal blocks or the RJ45 jack.

**3. Connect video out to your system** - Using standard coax cable connect from the video out BNC to your system as needed for viewing.

**4. Set DIP switch for distance** - Using the chart set the 8 position DIP switches on the VH451 for the distance of your twisted pair line plus any coax on each end. The modules are numbered to match the connections. Knowing the distance and setting the switch will save you time and provide you with the best possible picture. Settings listed are for standard communication cable. Should you be using wire gages less than 22 awg or **shielded wire** with less than 10 pair your setting may vary, call Nitek Tech Support for help.

## Switch setting for VH451 and Balun

Unmarked Positions are Off					Video Level Gain	Video Peaking		
Distance	Switch Position							
	1	2	3	4	5	6	7	8
<100-400 ft. (30-121 m)								
400-700 ft. (121-213 m)					ON			
700-900 ft. (213-274 m)			ON	ON	ON			
900-1,100 ft. (274-335 m)			ON	ON		ON		
1,100-1,300 ft. (335-396 m)			ON	ON		ON	ON	
>1,300 ft. (396 m)	ON	ON	ON	ON		ON		